

Gabelfräskopf Baureihe G30

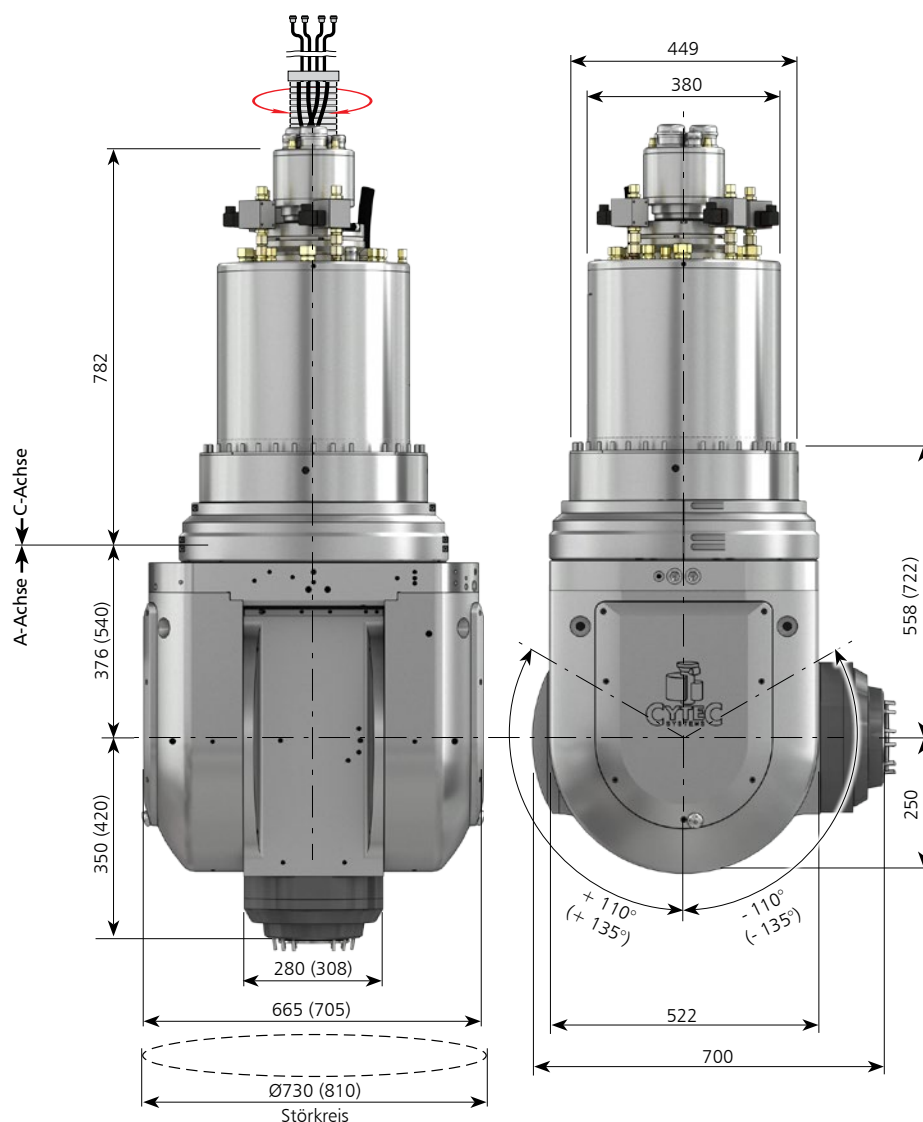

	A-Achse	C-Achse
Nenn-/Max. Drehmoment [Nm]:	2.000/3.700	1.830/3.550
Max. Drehzahl [min ⁻¹]:	60	60
Max. Beschleunigung [min ⁻¹ /s ²]:	7	5
Nennstrom [A]:	30	29
Klemmmoment 60 bar [Nm]:	7.000	
Schwenkwinkel [°]:	±110	±360/endlos
Messsystem:	absolut	absolut
Positioniergenauigkeit [“]:	±2,5	±2
Gesamtgewicht ca. [kg]:	1.200	



Optionen:



Automatischer Spindelwechsel



Automatischer Kopfwechsel



Drehfräsfunktion



Vertikaler Vorsatzkopf



Universalkopf

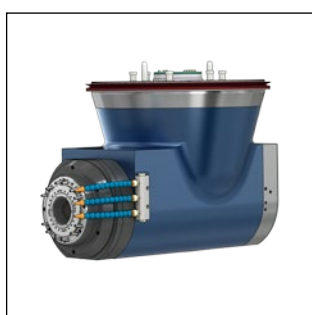

Horizontalkopf



Frässpindel Baureihe	CS-40-238-S	CS-42-238-S	CS-70-238-S	CS-75-260-S	CS-110-260-A
Leistung S1/S6 [kW]:	40/48	42/55	70/90	75/94	110/138
Nenn Drehzahl [min ⁻¹]:	1.350	1.000	7.000	1.600	1.600
Drehmoment S1/S6 [Nm]:	280/340	400/525	85/105	484/620	700/824
Max. Drehzahl [min ⁻¹]:	15.000	8.000	22.000	10.000	5.000
WZ-Schnittstelle:	HSK-A100	HSK-A100/ SK50/C8	HSK-A63	HSK-A100/ SK50	HSK-A100
Lagerschmierung:	Fett	Fett	Fett	Fett	Fett