

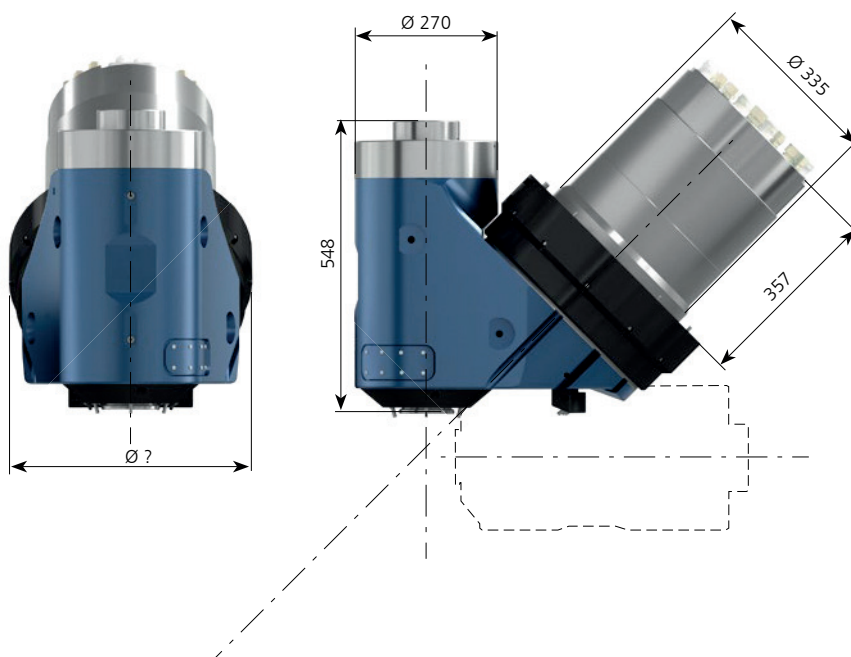

Universalfräskopf Baureihe M21 einachsig

| | A-Achse |
|-----------------------------|-----------|
| Nenn-/Max. Drehmoment [Nm]: | 900/1.680 |
| Nennstrom [A]: | 30 |
| Klemmmoment 50 bar [Nm]: | 4.000 |
| Schwenkwinkel [°]: | ±180 |
| Messsystem: | absolut |
| Positioniergenauigkeit [″]: | ±2 |
| Gesamtgewicht ca. [kg]: | 410 |



Motorspindeln

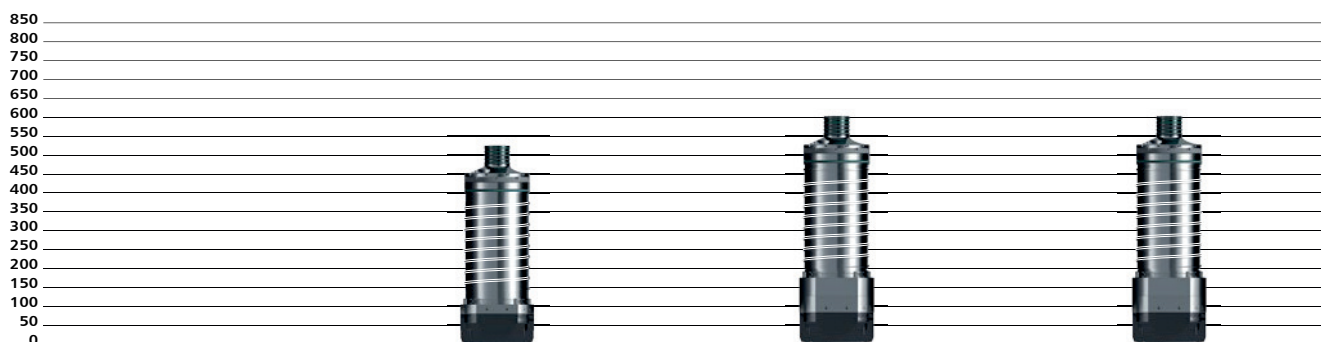

| Frässpindel Baureihe | CS-27-180-S | CS-34-180-S | CS-42-180-S |
|-------------------------------------|-------------|-------------|-------------|
| Leistung S1/S6 [kW]: | 27/32 | 34/43 | 42/53 |
| Nenn Drehzahl [min ⁻¹]: | 2.000 | 2.000 | 2.000 |
| Drehmoment S1/S6 [Nm]: | 130/170 | 170/220 | 201/253 |
| Max. Drehzahl [min ⁻¹]: | 12.000 | 12.000 | 12000 |
| WZ-Schnittstelle: | HSK-A100 | HSK-A100 | HSK-A100 |
| Lagerschmierung: | Fett | Fett | Fett |

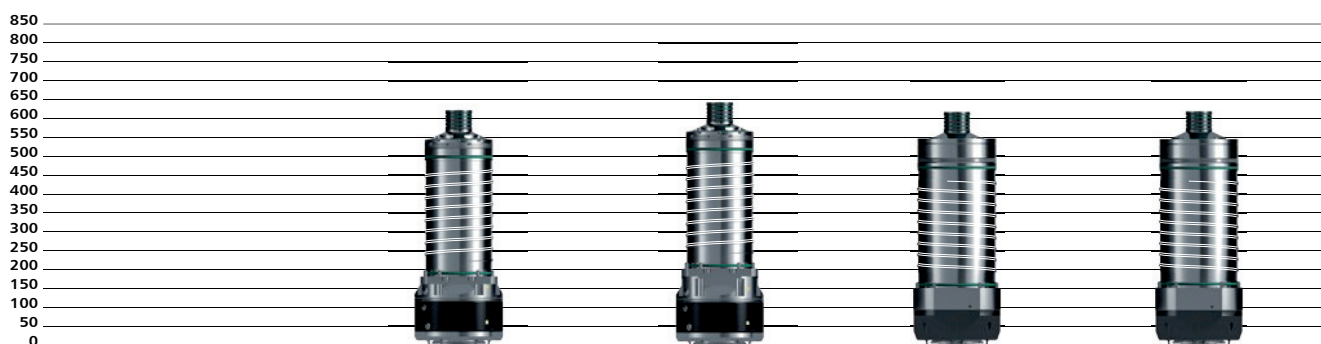

| Frässpindel Baureihe | CST-27-180-S | CST-42-180-S | CS-40-200-S | CS-50-200-S |
|-------------------------------------|--------------|--------------|-------------|-------------|
| Leistung S1/S6 [kW]: | 27/32 | 42/53 | 40/50 | 50/64 |
| Nenn Drehzahl [min ⁻¹]: | 2.000 | 2.000 | 2.400 | 2.000 |
| Drehmoment S1/S6 [Nm]: | 130/170 | 201/253 | 160/200 | 240/300 |
| Max. Drehzahl [min ⁻¹]: | 10.000 | 10.000 | 15000 | 8000 |
| WZ-Schnittstelle: | HSK-T63 | HSK-T100 | HSK-A100 | HSK-A100 |
| Lagerschmierung: | Fett | Fett | Fett | Fett |