

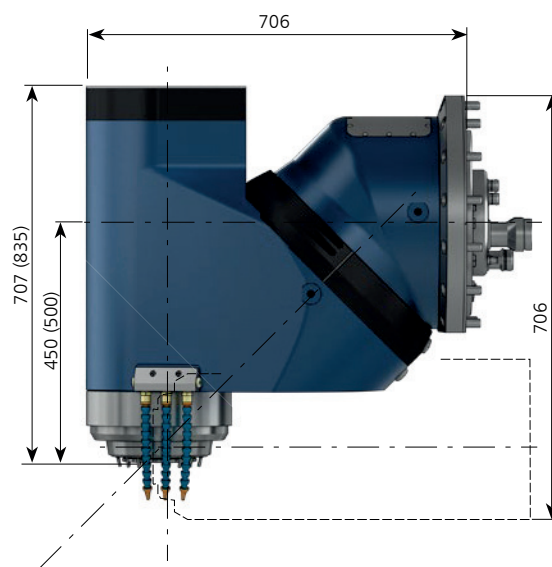

## Universalfräskopf Baureihe M21 XL einachsig

|                             | A-Achse   |
|-----------------------------|-----------|
| Nenn-/Max. Drehmoment [Nm]: | 780/1.470 |
| Nennstrom [A]:              | 30        |
| Klemmmoment 50 bar [Nm]:    | 2.500     |
| Schwenkwinkel [°]:          | ±190      |
| Messsystem:                 | absolut   |
| Positioniergenauigkeit ["]: | ±2        |
| Gesamtgewicht ca. [kg]:     | 840       |

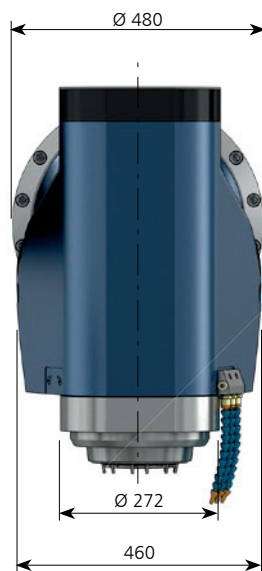

## Motorspindeln

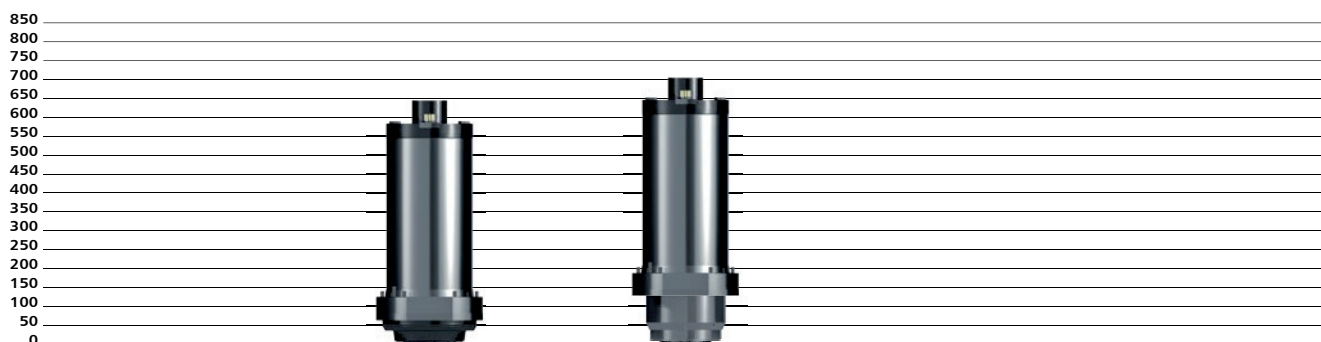

| Frässpindel Baureihe                | CS-50-238-S | CSG-50-300-S           |
|-------------------------------------|-------------|------------------------|
| Leistung S1/S6 [kW]:                | 50/63       | 50/63                  |
| Nenn Drehzahl [min <sup>-1</sup> ]: | 2.000       | 5.700                  |
| Drehmoment S1 [Nm]:                 | 248         | 265 (i=1), 795 (i=3)   |
| Drehmoment S6 [Nm]:                 | 315         | 334 (i=1), 1.002 (i=3) |
| Max. Drehzahl [min <sup>-1</sup> ]: | 15.000      | 7.000                  |
| WZ-Schnittstelle:                   | HSK-A100    | HSK-A100               |
| Lagerschmierung:                    | Fett        | Fett                   |